

**45° VERTICAL BENDS**

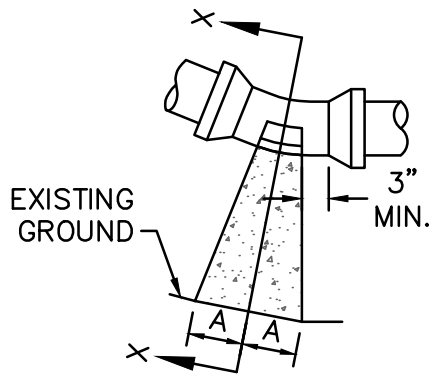

**PLAN BENDS**

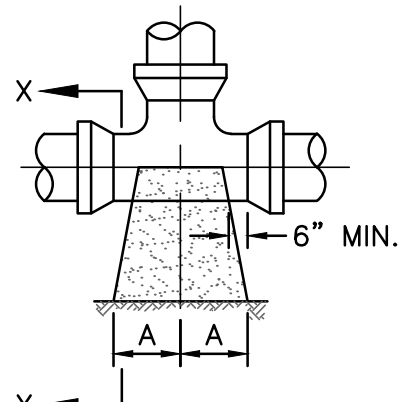

**PLAN TEES**

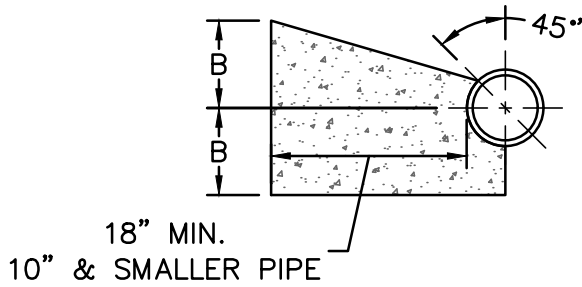

**18" MIN.  
10" & SMALLER PIPE**

**SECTION X-X  
BENDS & TEES**

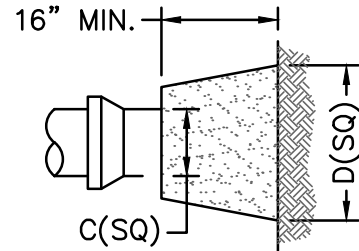

**PLAN & ELEVATION PLUGS**

SIZE	90 BENDS		45 BENDS		22-1/2 BENDS		TEES/PLUGS		45 VERT. BENDS
	A	B	A	B	A	B	A	B	
3"	8"	6"	5"	6"	3"	7"	6"	8"	27"
4"	8"	9"	5"	8"	3"	11"	6"	9"	28"
6"	14"	11"	9"	9"	8"	8"	12"	9"	36"
8"	16"	16"	12"	12"	10"	13"	14"	13"	42"
10"	18"	22"	15"	14"	14"	16"	18"	15"	50"
12"	20"	28"	18"	17"	16"	16"	22"	18"	62"
14"	26"	29"	21"	19"	18"	18"	26"	20"	72"
16"	33"	29"	25"	21"	20"	21"	32"	21"	83"
18"	40"	30"	28"	24"	22"	23"	36"	24"	88"

**NOTES:**

1. THRUST BLOCKING IS NOT PERMITTED EXCEPT IN SPECIAL INSTALLATIONS WHERE DESIGNED BY ENGINEER AND APPROVED BY CFPUA.
2. ALLOW 7-DAY MINIMUM CONCRETE CURE TIME BEFORE PLACING LOAD ON THRUST BLOCK
3. BASED ON 160 PSI TEST PRESSURE AND 2,000 PSF SOIL BEARING CAPACITY.
4. ALL BEARING SURFACES TO BE CARRIED TO UNDISTURBED GROUND.
5. PIPE & FITTINGS TO BE WRAPPED IN 10 MIL PLASTIC PRIOR TO THRUST BLOCK BEING POURED.

DETAIL:	
THRUST BLOCK	
SCALE: NOT TO SCALE	CFPUA DETAIL DATE:
CFPUA REV. No: 1	01/01/19

**CAPE FEAR PUBLIC UTILITY AUTHORITY**  
 235 GOVERNMENT CENTER DRIVE  
 WILMINGTON, NC 28403  
 OFFICE: (910)332-6560

Stewardship. Sustainability. Service.

DETAIL NO:
<b>WS-13</b>
SHEET NO:
-